

---

# INTENSE PULSED ELECTRON BEAM: APPLICATION TO MATERIALS STUDY.

L. Voisin<sup>1</sup>, B. Birel<sup>1</sup>, T. Desanlis<sup>1</sup>, A. Galtié<sup>1</sup>, D. Hebert<sup>1</sup>,  
J.P. Lasserre<sup>1</sup>, Y. Loreau<sup>1</sup>, A. Serrand<sup>1</sup>,  
C. Noel<sup>2</sup>, O. Pierret<sup>2</sup>.

*1: CEA/CESTA, BP 2, 33114 Le Barp, France*

*2: CEA/DIF/PEM 51490 Pontfaverger-Moronvilliers*

# OUTLINE

---



énergie atomique • énergies alternati

- Introduction
- Presentation of the generator Cesar
- Different methods used to analyze the beam
- Comparison between simulation and experiments
- Summary
- Future work

# Introduction 1/2



energie atomique • energies alternatives

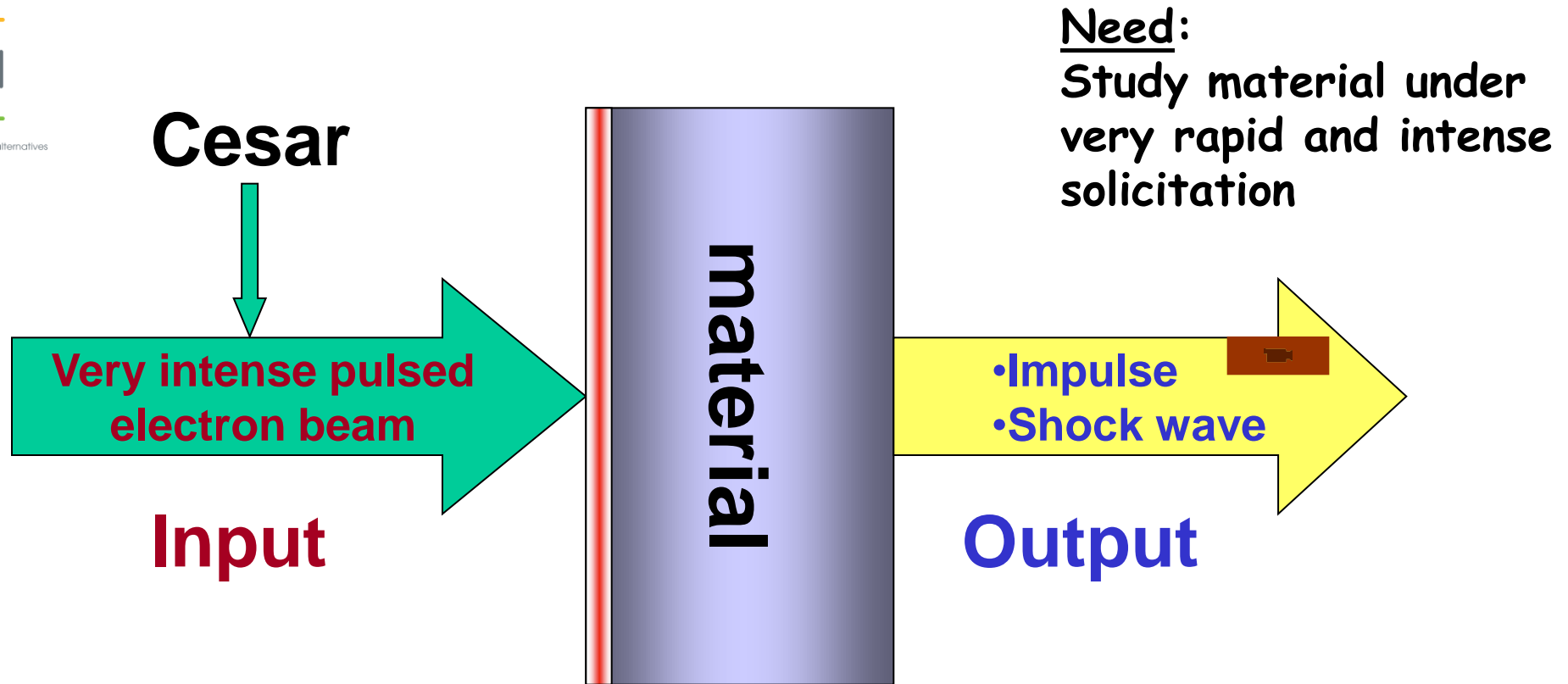

**Output:**

- Function of the material: what we want to determine
- Function of the parameters of the beam

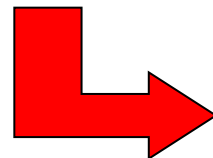

**Need to know the beam well!!!**

- Intensity
- Energy  $e^-$
- Spatial distribution

# Introduction 2/2

---



énergie atomique • énergies alternati

- Studied Parameters:
  - Energy of the electrons
    - Time resolved spectrometer
  - Spatial distribution of the energy
    - Time integrated X-ray imagery
    - Time resolved Infrared imagery
    - Multi-way shock wave measurement

# CESAR



energie atomique • energy alternatives

Voltage and current sensors

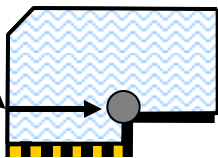

Magnetic

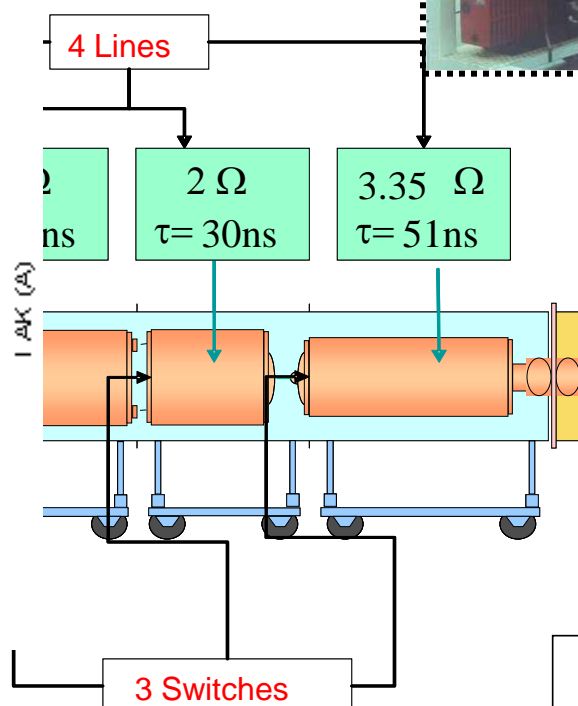
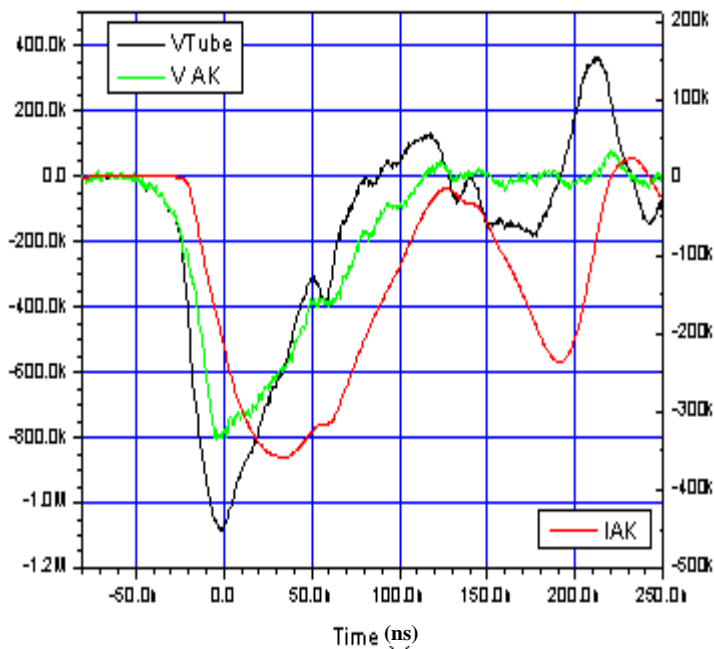

20 stages  
50 kJ à 120 kV

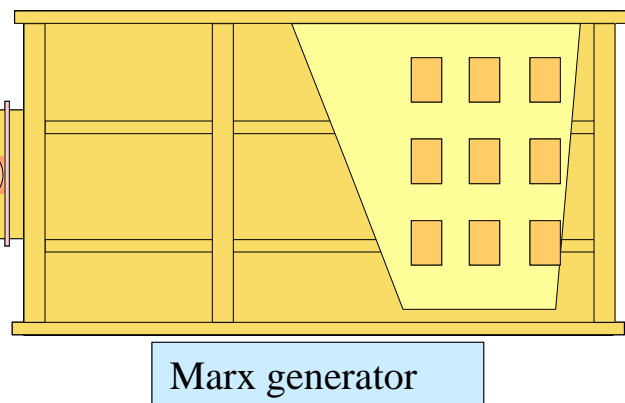

4 coaxial water lines separated with 3 closing switches

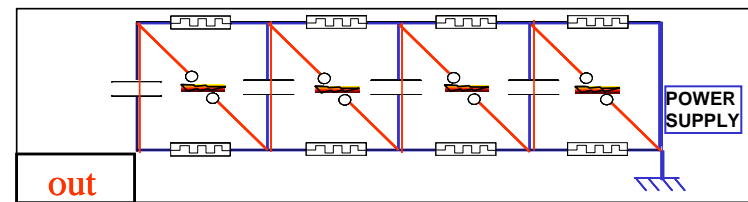

— Charging circuit  
— Discharging circuit

# OUTLINE

---



énergie atomique • énergies alternatives

- Introduction
- Presentation of the generator Cesar
- Different methods used to analyze the beam
  - Time resolved spectrometer
- Comparison between simulation and experiments
- Summary
- Future work

# Spectrometry: requirements

---



énergie atomique • énergies alternatives

- The energy of the electrons is given by the voltage between the cathode and the anode
- The measurement can't be made near the cathode
- A correction ( $V_{ak} = V_p - L di/dt$ ) must be made  
(L is the self inductance between point of measure and the cathode).
- The goal of the spectrometer is to validate the calculated  $V_{ak}$  value by a direct measure

# SPECTROMETER



energie atomique • energies alternatives

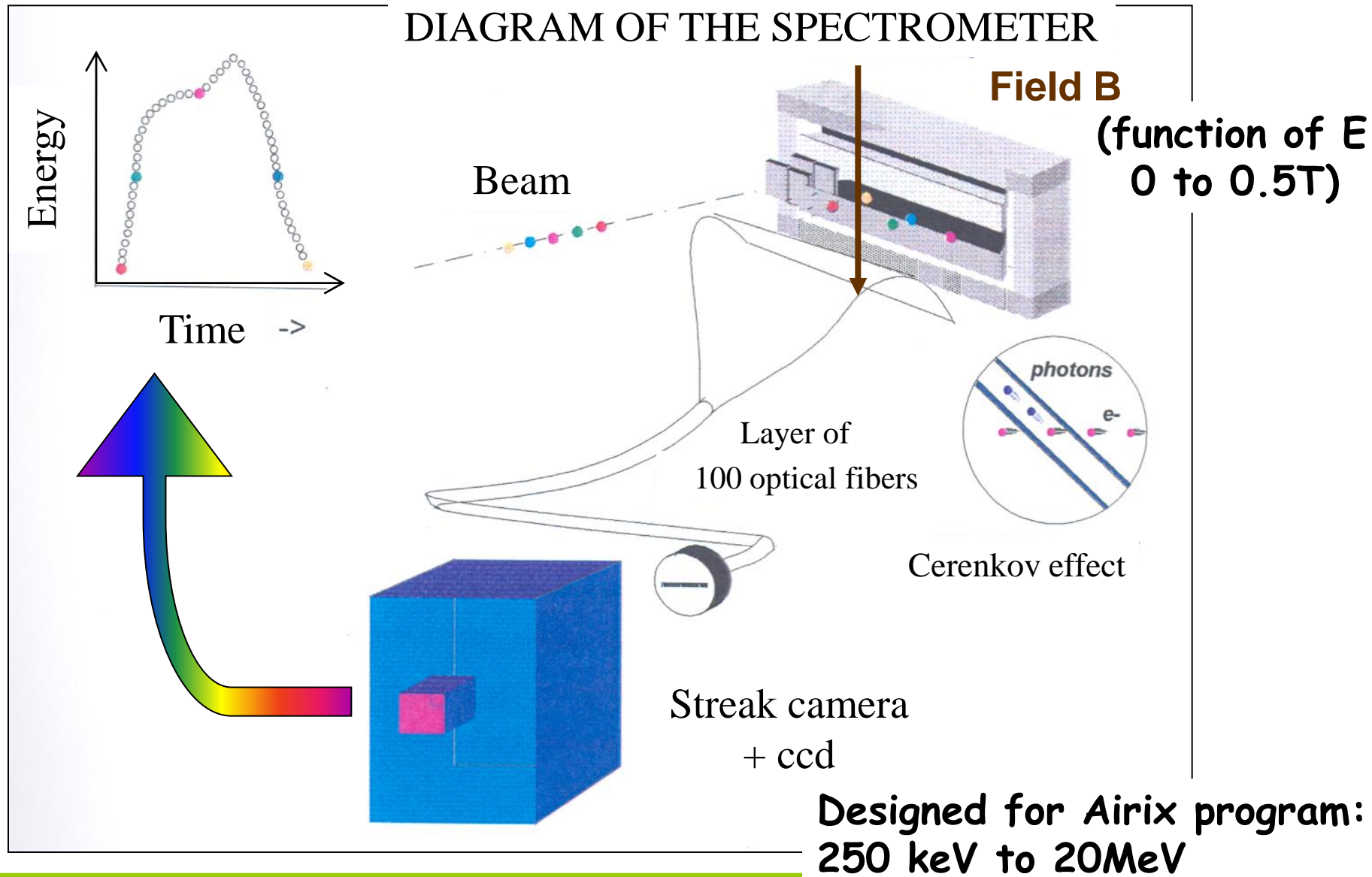

# Pictures of the Spectrometer

cea

nergie atomique

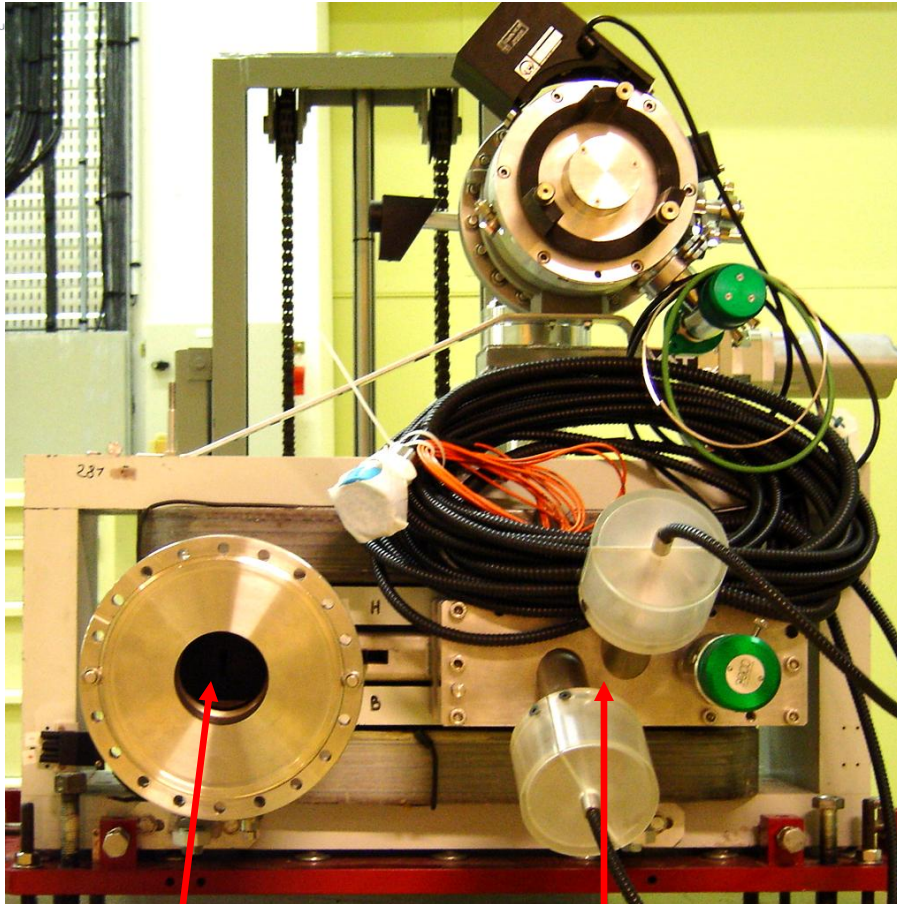

**Admission of  
the beam**

**Analyze area**  
(2# layers → 2 levels of resolution)  
**E±5% / E±50%**



**Spectrometer  
plugged into Cesar**

# Spectrometry: results



energie atomique • energies alternatives

Superposition of  $V_{ak}$  and energy given by the spectrometer

Even small resolution:  
Ex.  $400 < (\text{keV}) < 850$   
Can't see all the dynamic of the signal.  
Several shoots with #values of B were necessary to check between 300 and 900 keV

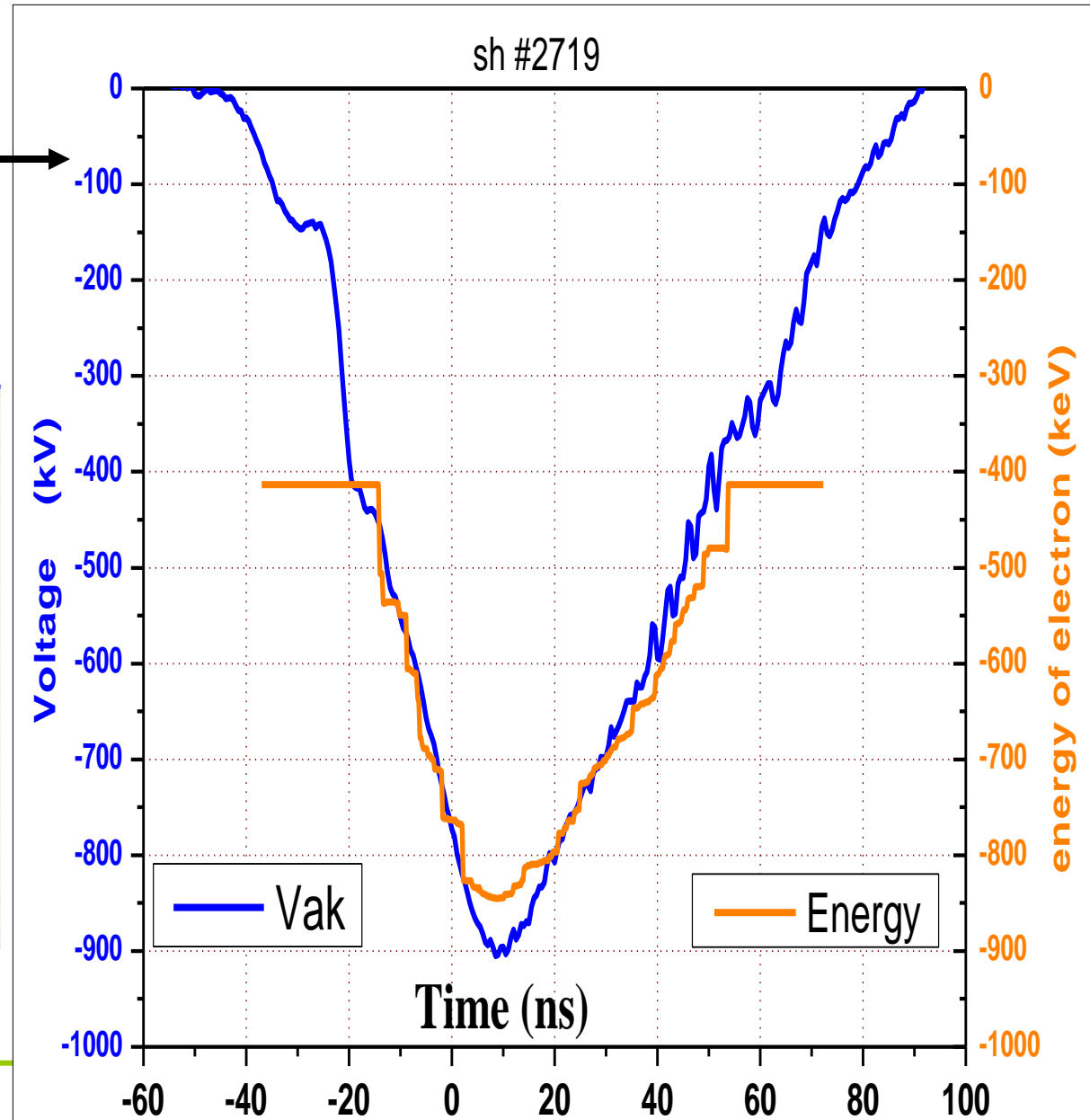

# OUTLINE

---



énergie atomique • énergies alternatives

- Introduction
- Presentation of the generator Cesar
- Different methods used to analyze the beam
  - Spatial energy distribution
- Comparison between simulation and experiments
- Summary
- Future work

# X-RAY IMAGERY



energie atomique • energies alternatives

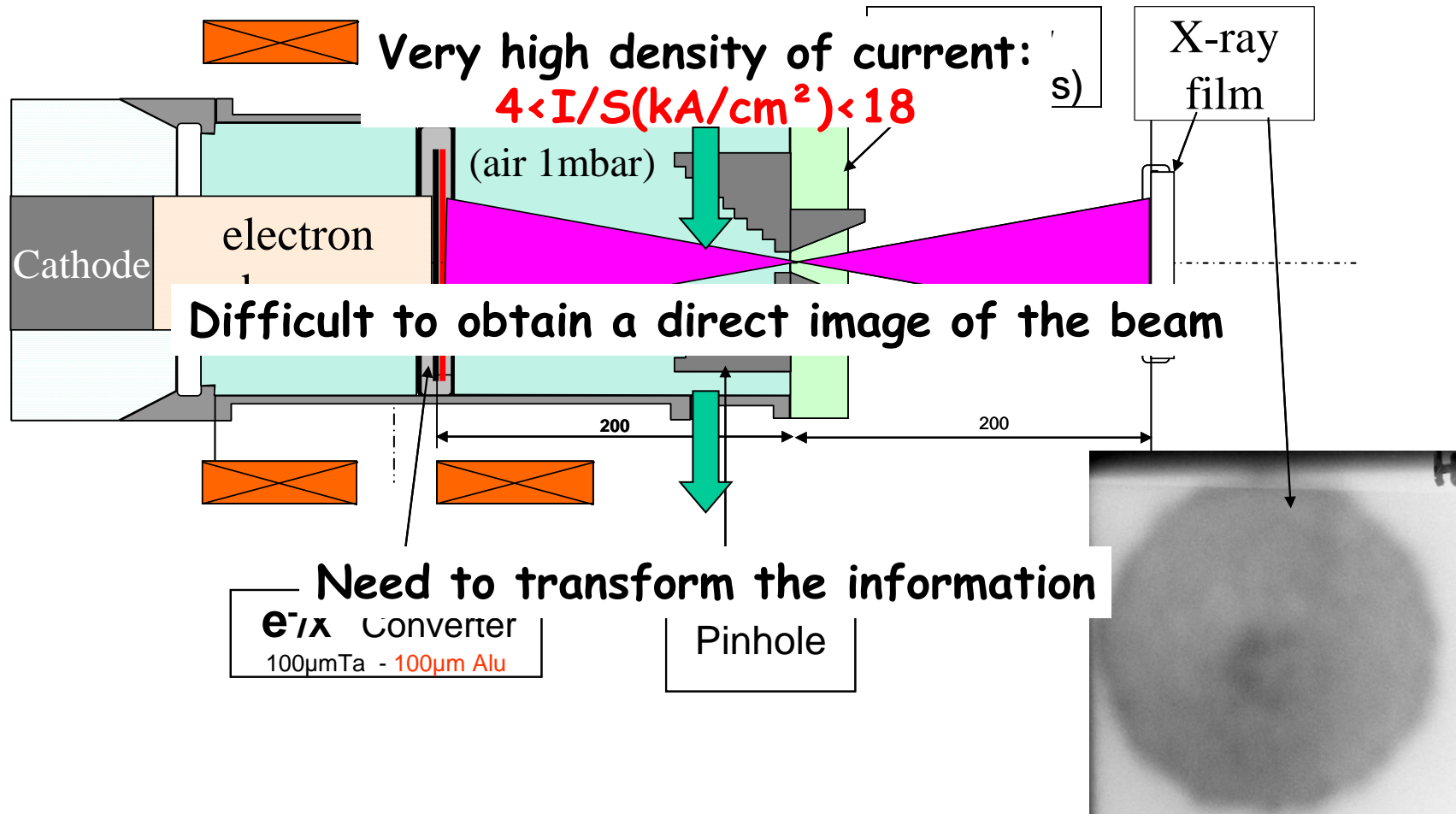

# Some X-Ray pictures

cea

energie atomique • energies alternatives

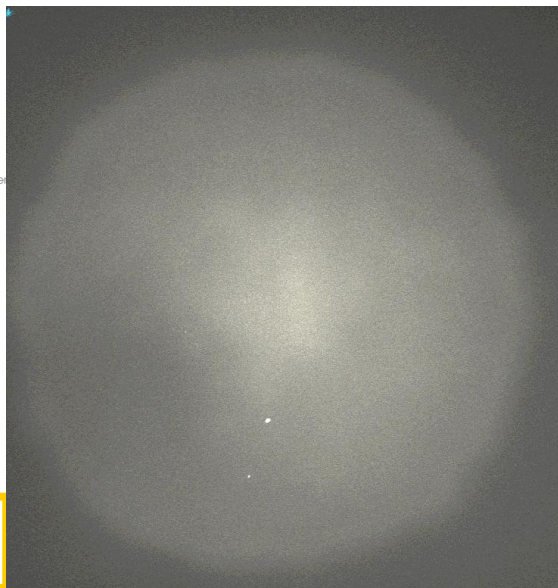

2837

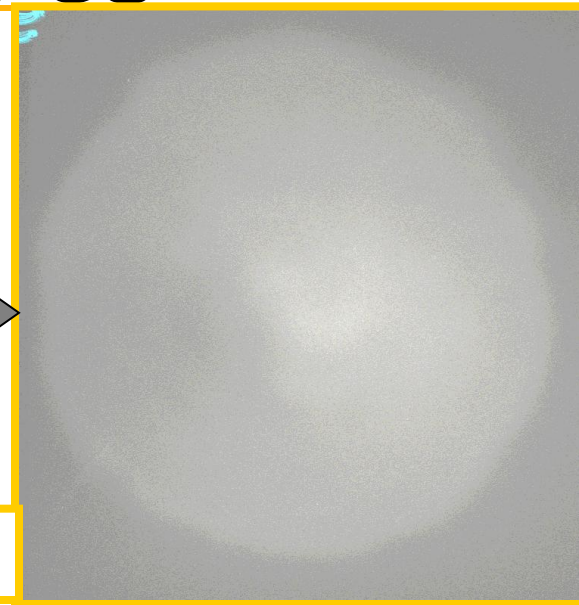

2838

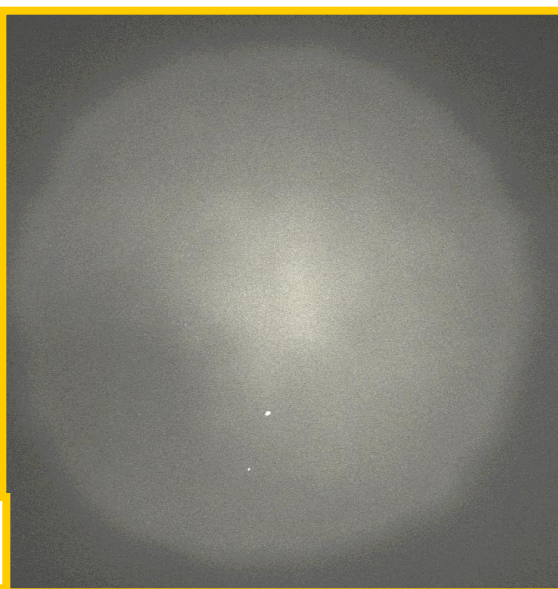

2839

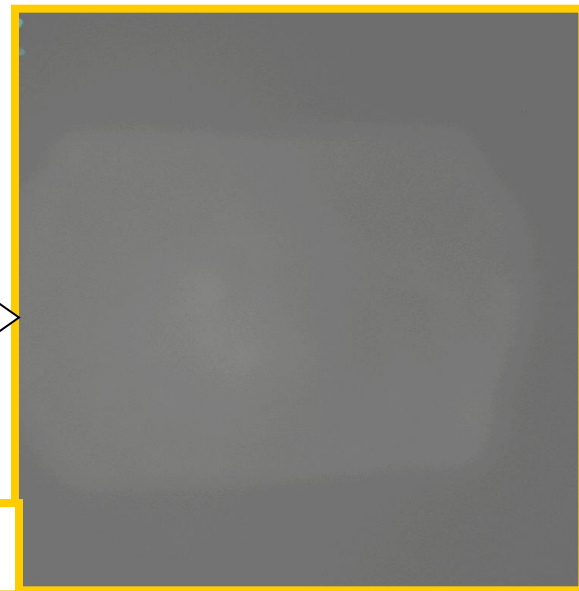
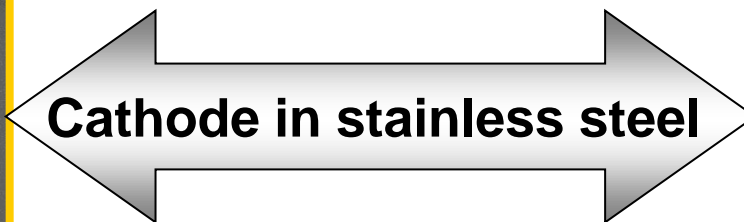

2840

# Comparison between cathode materials

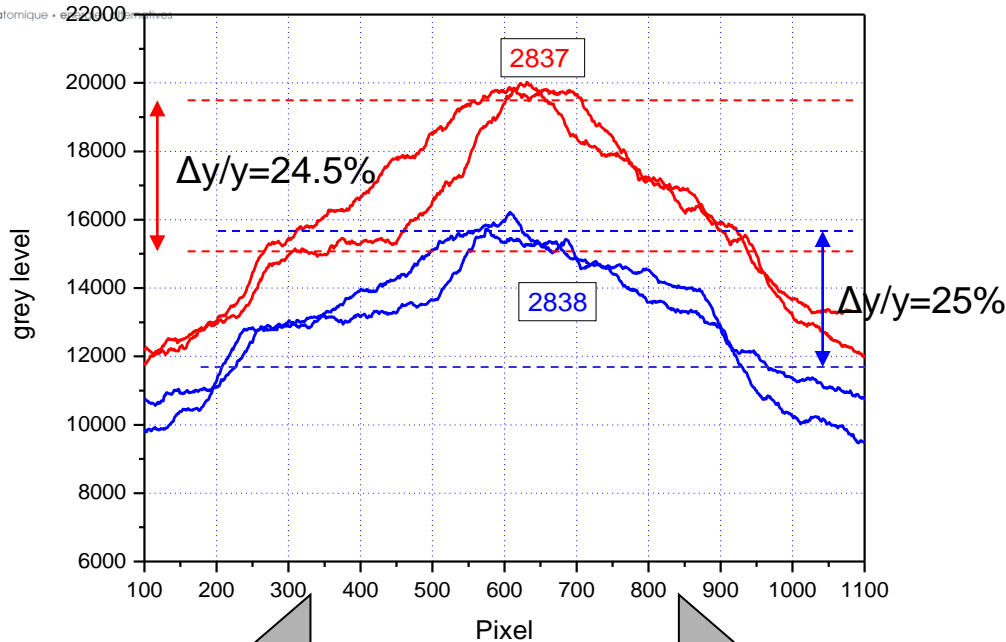

Cathode in Graphite

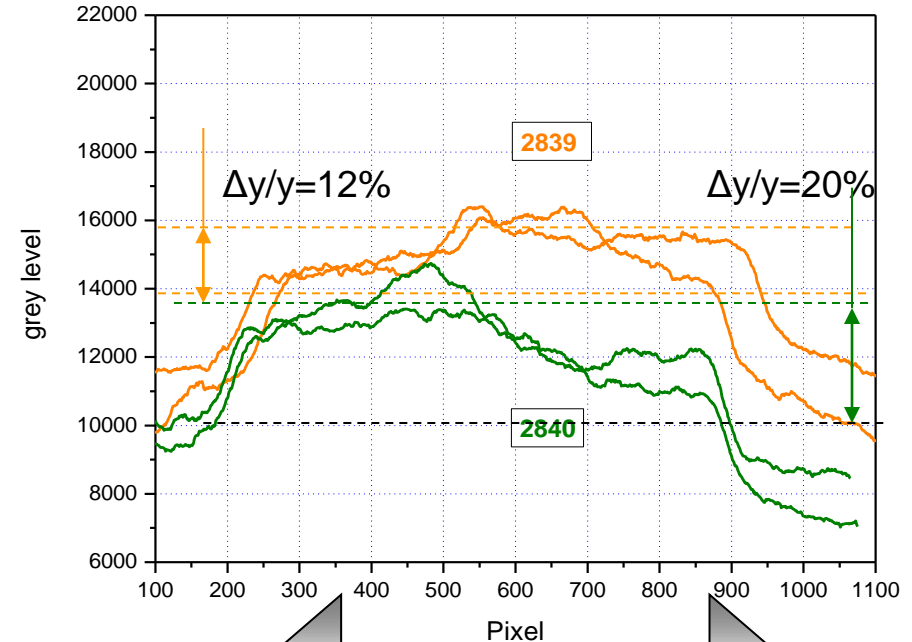

Cathode in stainless

By taking into account the main parts of the images (plateau),  
in these conditions of density of energy:  
Results with stainless cathode are more homogenous than with  
graphite cathode.

# OUTLINE

---



énergie atomique • énergies alternatives

- Introduction
- Presentation of the generator Cesar
- Different methods used to analyze the beam
  - Spatial energy distribution
    - Infrared Imagery
- Comparison between simulation and experiments
- Summary
- Future work

# Infrared imagery



energie atomique • energies alternatives

## Possibility time resolved

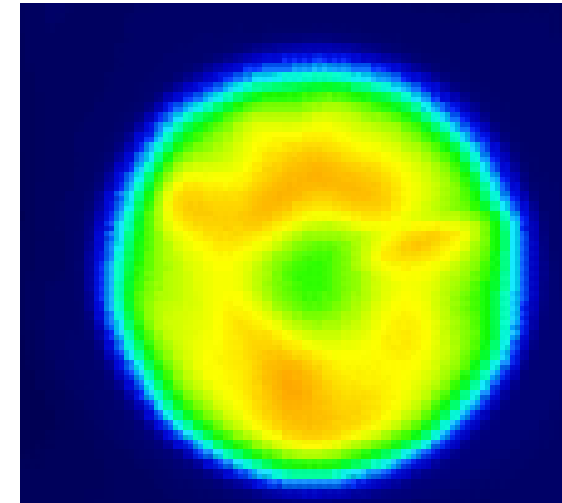
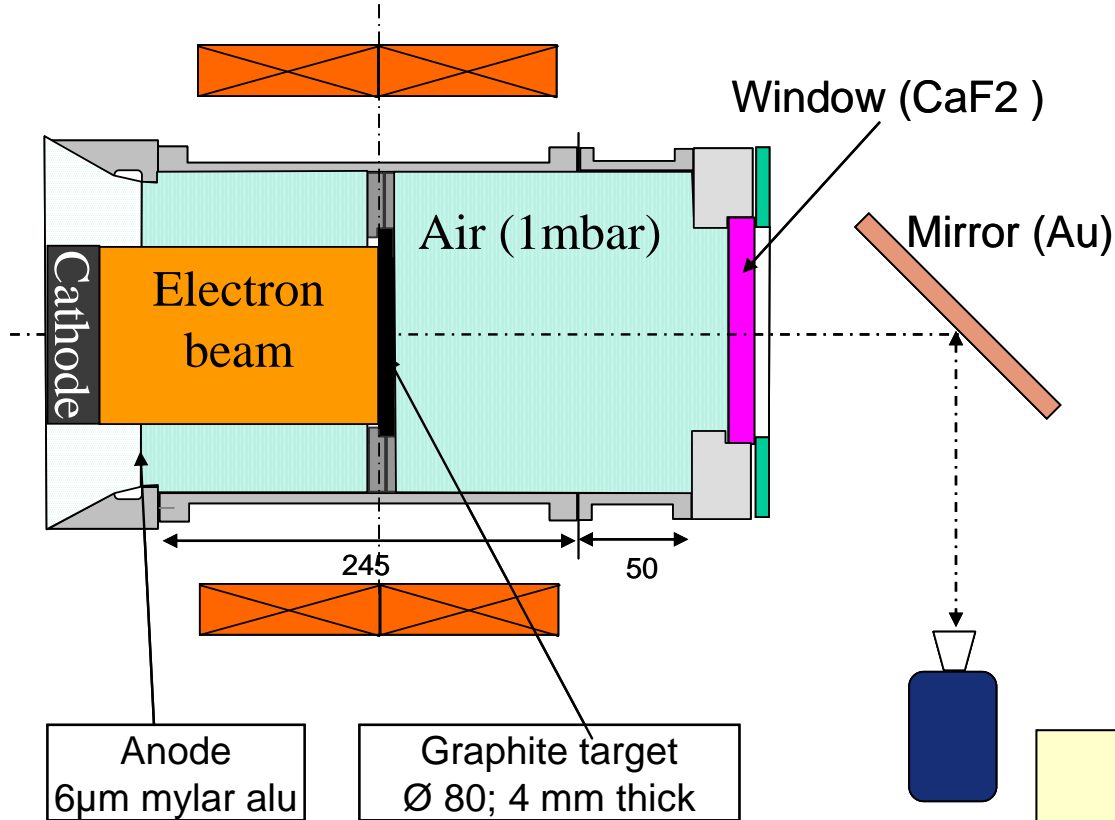

## Infrared Camera CEDIP

Jade III MWIR,  
64x120 pixels  
=> Acquisition frequency : **265Hz**

# IR picture at t=0



nergie atomique

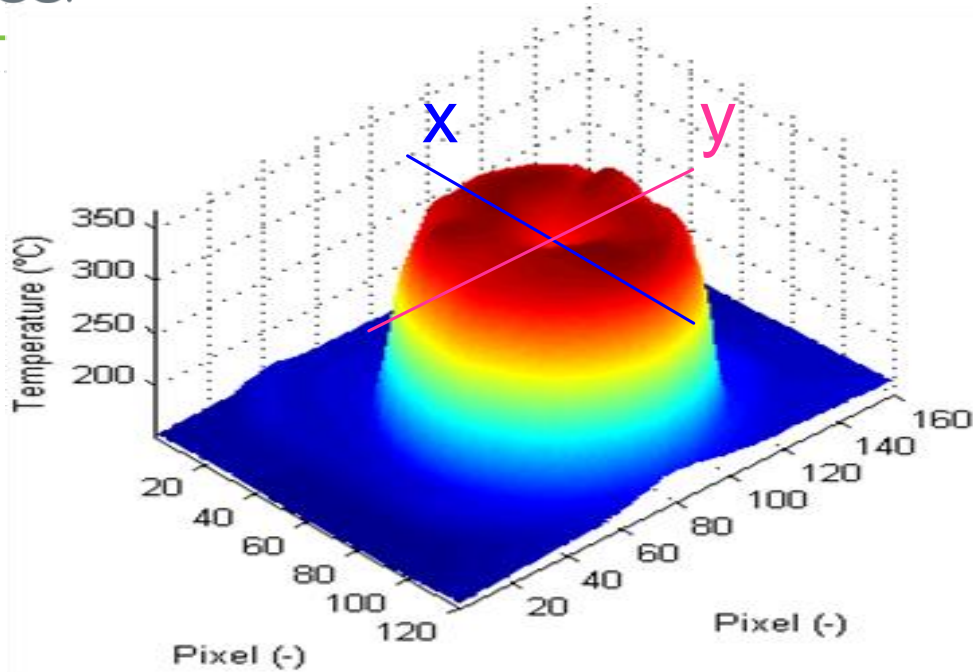

3d representation

X and y sections at t=0

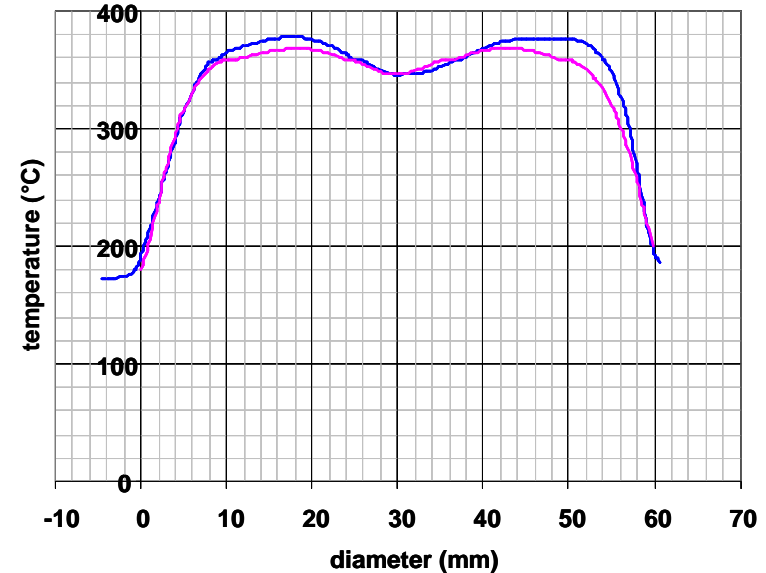

X and y cross sections

## Experimental conditions:

Cathode in graphite ( $\varnothing=95\text{mm}$ )  
 $F=100\text{cal/cm}^2$

**Very different between X-ray and IR imageries.**

- profiles shaped like a crown
- could be due to ejection of matter at the front surface

# OUTLINE

---



énergie atomique • énergies alternati

- Introduction
- Presentation of the generator Cesar
- Different methods used to analyze the beam
  - Spatial energy distribution
    - Shock wave measurement
- Comparison between simulation and experiments
- Summary
- Future work

# Interface velocimetry measurement



energie atomique • energies alternatives

In order to measure the shock wave generated by the electron beam in the material, we have been employing a velocimeter using heterodyne technique [1,2]

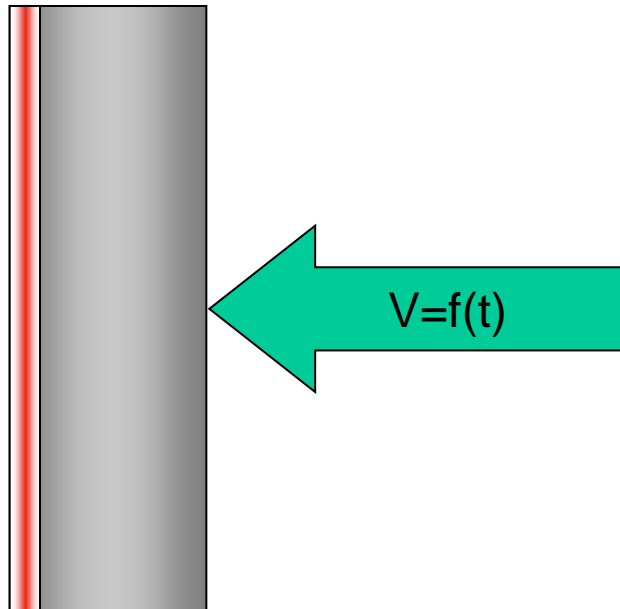

1: Strand et al., Velocimetry using heterodyne techniques, proc. of SPIE, vol.5580

2: Mercier et al, Photonic Doppler velocimetry in shock physics experiments, J. Phys.IV (2006), 805-812

# Interface velocimetry measurement



energie atomique • energies alternatives

## Main characteristics of the system :

- Fiber Lasers and Fiber components coming from communication industry ( $1.55\mu\text{m}$ )
  - $10\text{m/s} < \text{velocity} < \text{up to } 2000\text{m/s}$  (depending of the bandwidth of the digitizer)
  - 4 ways associated to one laser

**Block diagram of the system**

# Shock wave measurement



energie atomique • energies alternatives

- The results for the off-axis positions are very blurred

- The shock wave at the center is higher by a factor of +20/+40%

- Corresponding to the observations obtained with X-ray imageries.

Position of the points of velocity measurement at the rear surface

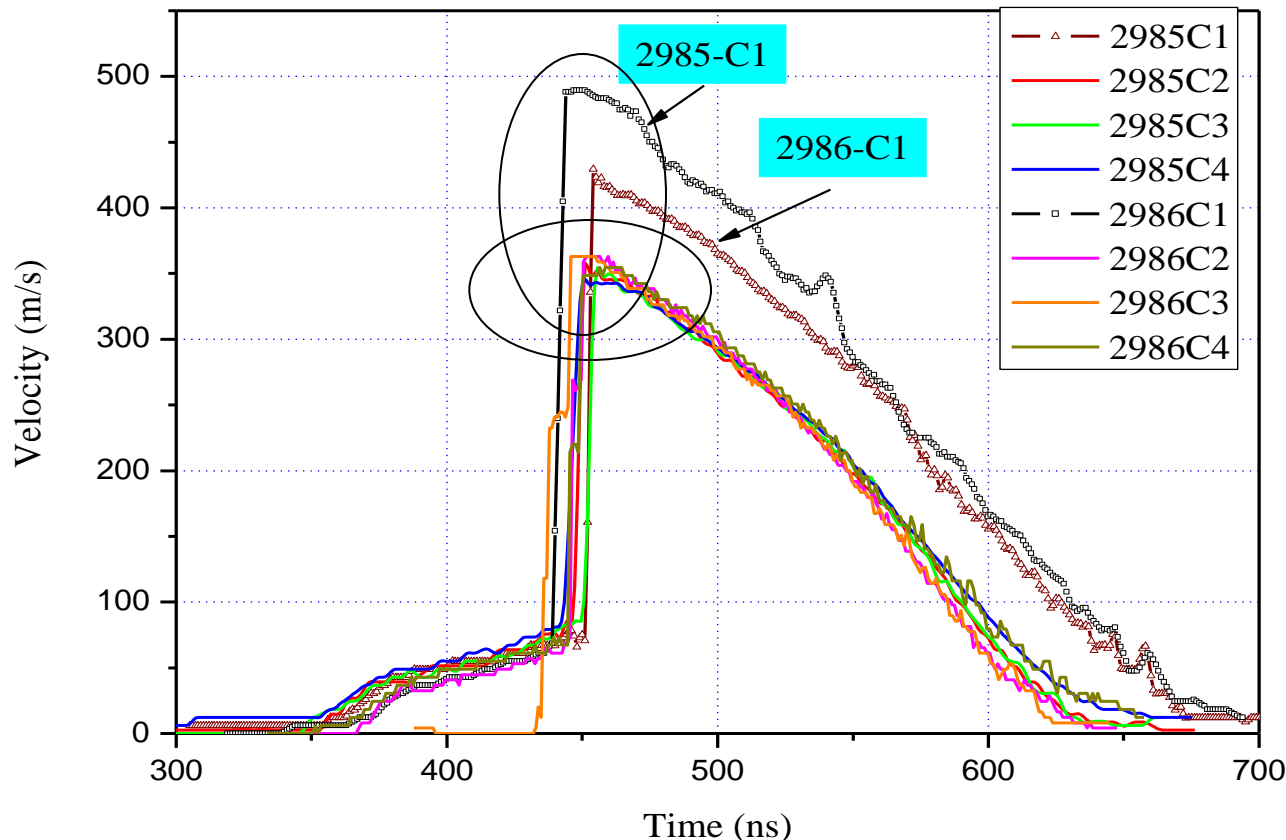
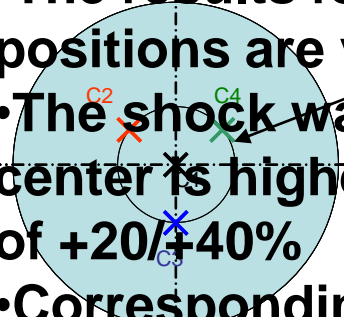

**Superposition of velocity measurements for Sh 2985 and 2986. Aluminum target.**

Experimental conditions:

Cathode in graphite ( $\varnothing=95\text{mm}$ )

$F=140\text{cal/cm}^2$

# OUTLINE

---



énergie atomique • énergies alternatives

- Introduction
- Presentation of the generator Cesar
- Different methods used to analyze the beam
- Comparison between simulation and experiments
- Summary
- Future work

# Comparison of 1d simulation with experimental signals



energie atomique • energies alternatives

- 2 levels of fluence were taken for simulations
- The relative difference fit quite well with the experimental results

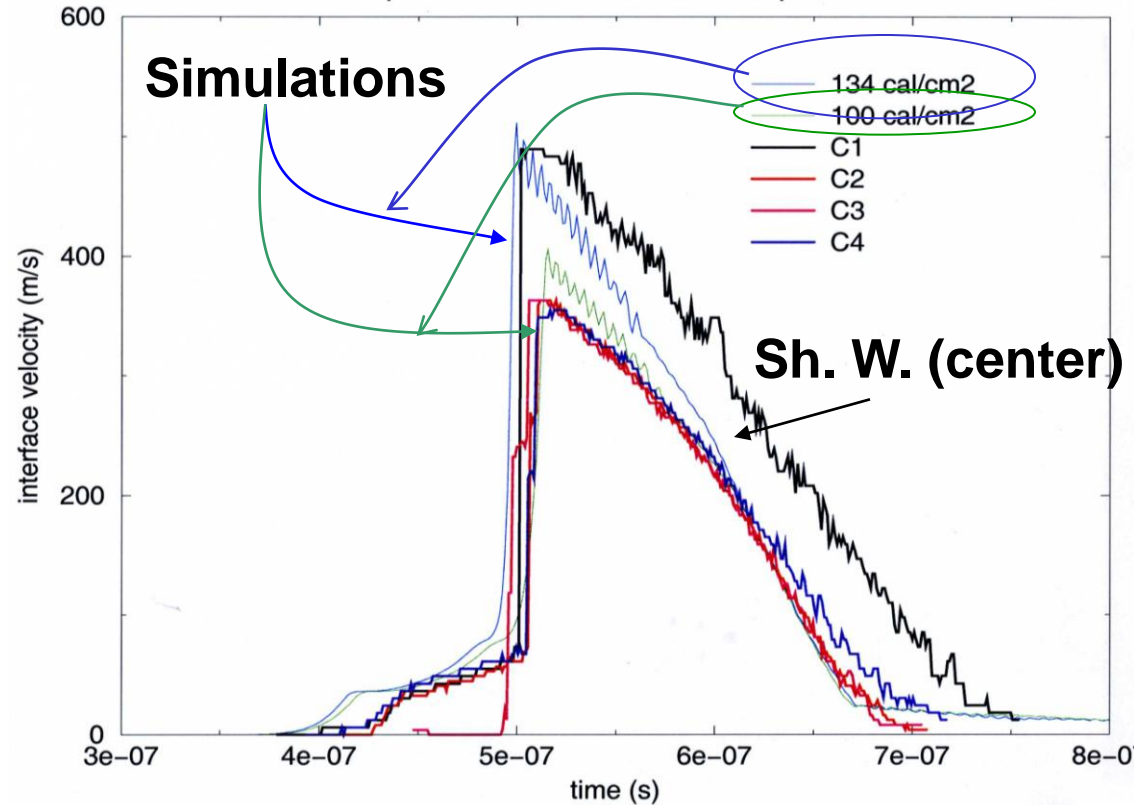

Superposition of 1d simulations and experimental signals (sh#2986)

# SUMMARY

---



énergie atomique • énergies alternatives

- Good agreement between spectrometer and anode cathode voltage measurement
- X-Ray imagery and shock wave measurement suggest that the density of energy could be higher on-axis as off-axis (for the analyzed conditions)
- The simulation agree this suggestion
- IR imagery have to advance. (modification of the material)

# Next Work

---



énergie atomique • énergies alternatives

- Simulate this experiment with a PIC Code (Magic© code under test now)
- Time resolved X-Ray imagery
- Replace the detection of the spectrometer to be able to measure under 300 keV.
- Multiply by 2 the number of shock wave measurements