



# Improved Methodology for Calculation of High Power Microwave System Efficiencies

John Krile

Magne Kristiansen

Center *for* Pulsed Power & Power Electronics  
Department of Electrical & Computer Engineering  
Texas Tech University, Lubbock, TX 79409-3102



# Motivation

- Typical methods for HPM source efficiency calculation:
  - Peak output power/Peak input power
  - Peak output power/Input power at time of peak output
- Useful given the difficulties obtaining HPM power envelope
- Power method shortcomings
  - Takes into account only the HPM source
  - Field operable system must include ancillary system efficiencies
  - In an isolated system energy is the limiting factor
- Energy based calculation more accurately describe the needs of the system in an operational environment



# Idealized HPM System

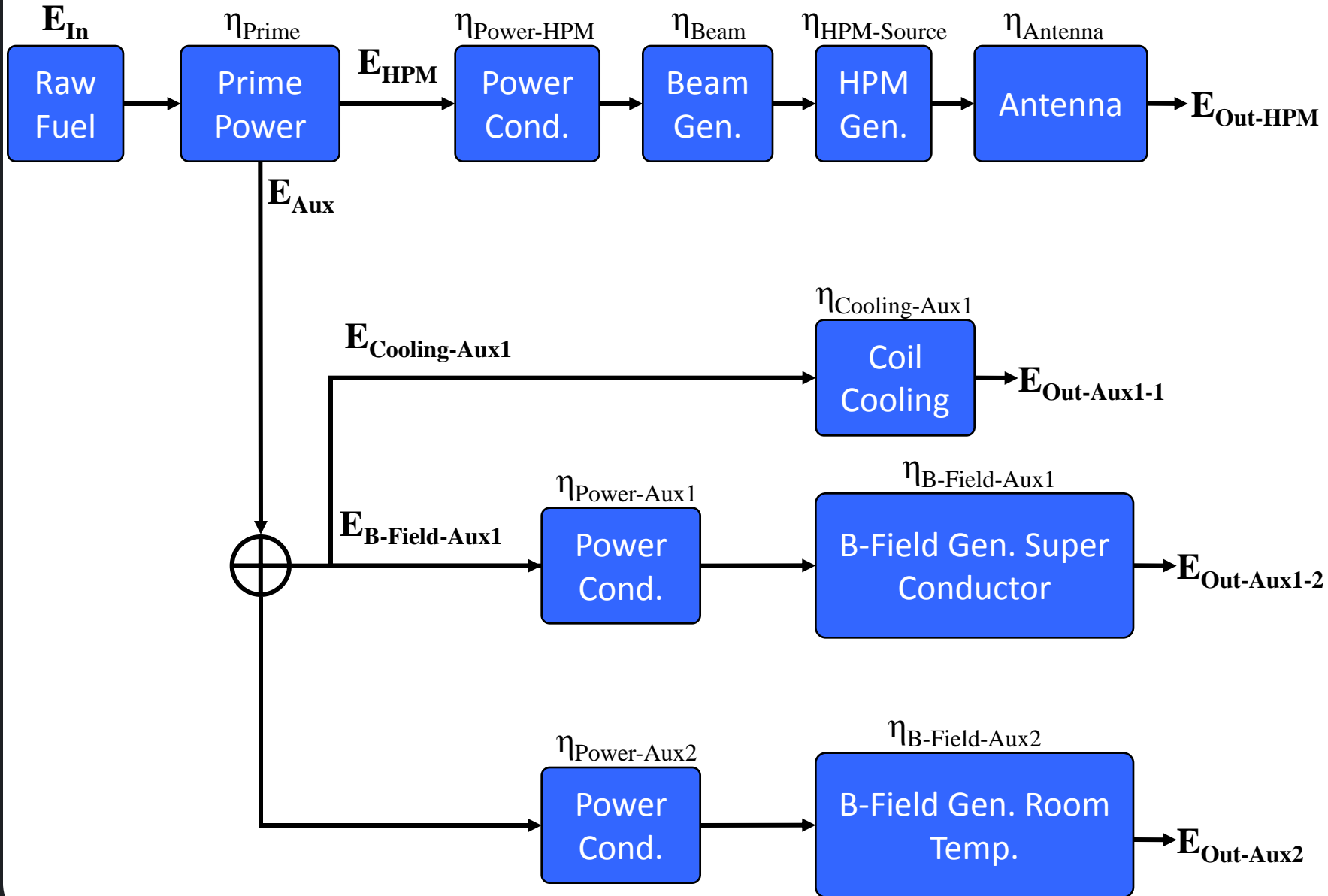



# Fuel to Prime Power - $\eta_{\text{Prime}}$

- Raw Fuel Sources
  - Diesel/Gas
  - Battery
  - Renewable (Wind, Solar)
  - Explosives
- Energy Conversion Methods
  - Large scale power plant (Power Grid)
  - Portable generators (Diesel, Turbine)
  - Switching power supply (Inverter)
  - Magnetic Flux Compression Generator (MFCG)



# Prime Power Efficiency - $\eta_{\text{Prime}}$

- Energy Efficiencies
  - Large scale power plant (Power Grid)
    - 30% to 65% Depending on age, technology, fuel, etc.
  - Portable generators (Diesel, Turbine)
    - 40% to 50%
  - Switching power supply (Inverter)
    - Burst Mode
      - 40% to 50%
    - Slow Charge
      - Greater than 95%
  - Magnetic Flux Compression Generator (MFCG)
    - On the order of 0.2%
    - Very Large Energy Density



# Power Conditioning Efficiency – $\eta_{\text{Power}}$

- Power Conditioning Systems
  - Marx Generator
    - Including impedance matching / Pulse shaping
    - 80% - 90%
  - Linear Transformer Driver (LTD)
    - 60% - 70%
  - Pulse Forming Line (PFL) with Switch
    - 70% - 80%
  - Pulse Forming Network (PFN) with Switch
    - 70% - 80%
  - Capacitive Store
    - Greater than 90%
  - Modulator
    - 40% to > 95%



# Beam, Source, Antenna Efficiency

- Driving / e-beam pulse width
  - Typically 2 to 10 longer than HPM output
  - Assuming ideal square pulses
    - Energy efficiencies from 10% to 50%
- Source efficiency ( $\eta_{\text{HPM-Source}}$ )
  - MWCG – 20% to 50%
  - RDG – 5% to 20%
  - BWO – 15% to 35%
  - Magnetron – 30% to 70%
  - MILO – 1% to 11%
  - Klystrons – 35% to 60%
  - Reltrons – 40% - 50%
  - Vircator – 1% to 12%
  - Gyrotrons – 35% to 55%
- Overall source efficiency
  - 0.1% to 30%
- Electron Beam Gen. ( $\eta_{\text{Beam}}$ )
  - Greater than 90%
- Antenna Efficiency ( $\eta_{\text{Antenna}}$ )
  - Directivity
  - Breakdown Mitigation
  - Size
- Radiated Energy Efficiencies
  - Given reasonable sizes constraints
  - 50% to 80%

MWCG – Multiwave Cerenkov Generator

RDG – Relativistic Diffraction Generator

MILO – Magnetically Insulated Line Oscillator



# Idealized HPM System

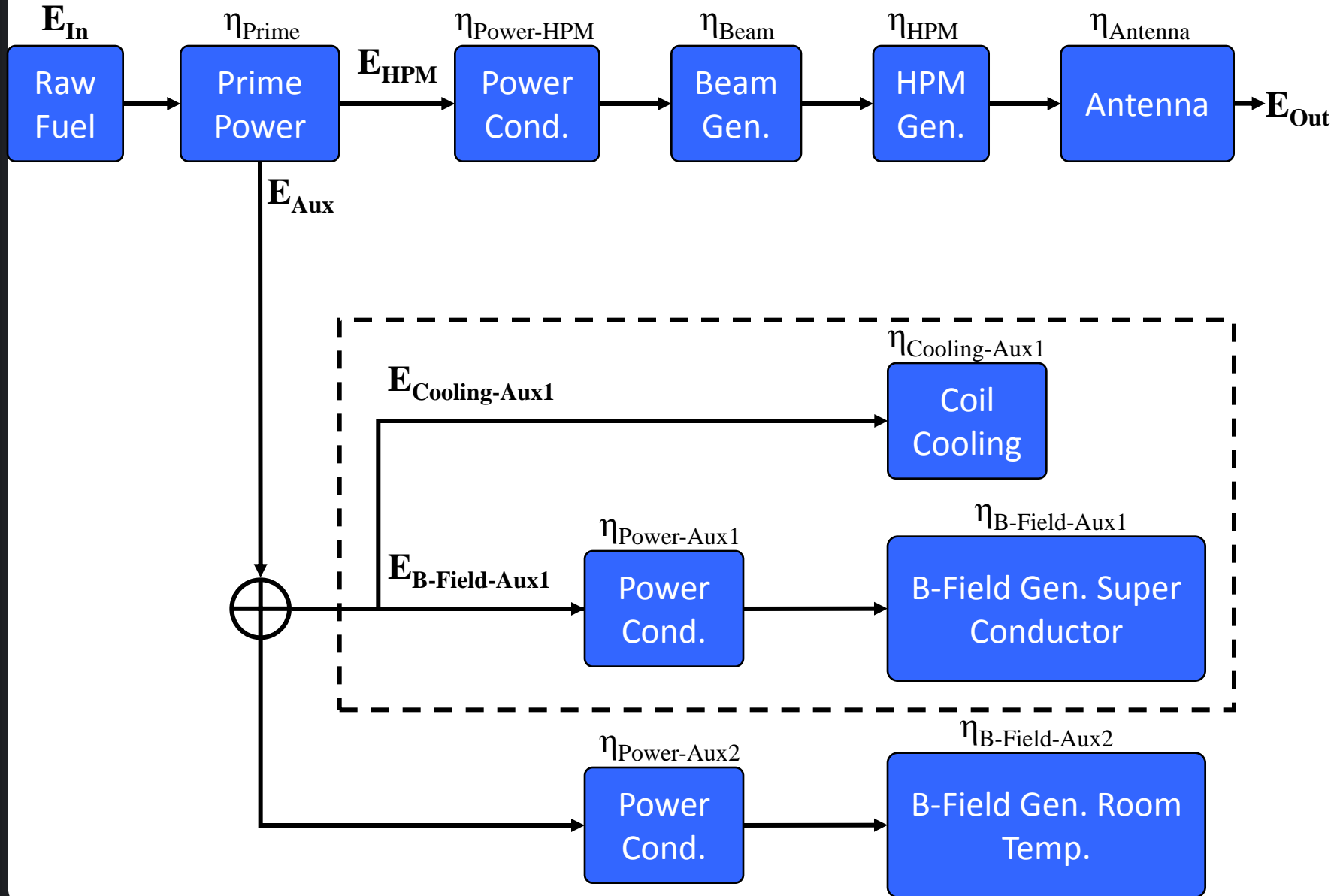



# Super Conductor Cooling– $\eta_{\text{Cooling-Aux1}}$

- Liquid Cooling
  - Liquid Nitrogen/Helium
  - Energy needed to create/transport gas
  - **Not ideal for field operable systems**
- Closed Cycle Refrigeration
  - Two stage GM (Gifford-McMahon) Unit
  - $< 4\text{K}$  Operating Temperature
  - $< 1.5\text{W}$  Cooling Power (at  $< 4\text{K}$ )
  - $45\text{ W}$  Cooling Power (at  $50\text{K}$ )
  - $8.5\text{kW}$  System Power Consumption
  - 5 to 15 hour Cool Down Time (Real system)
  - **Energy Requirements**
    - **$170\text{MJ}$  to  $475\text{MJ}$  for one shot**
    - **$510\text{kJ}$  for every minute thereafter**
  - **Energy Efficiency**
    - **$0.5\%$**



# Super Conductor Power – $\eta_{\text{Power-Aux1}}$

- Switching and Linear Supplies
  - Current power supply technology very mature
  - Persistent mode operation
    - No additional energy needed after ramp up
      - Excluding Cooling
  - Ramp up can take minutes to hours
    - To prevent quenching
- Energy Efficiency
  - 30% to 50% at full power
- Energy Requirements (During ramp-up)
  - 50kJ to 500kJ - Dependent on final current
- Energy Requirements (During operation)
  - 1kJ to 10kJ per minute - Dependent on final current



# Idealized HPM System

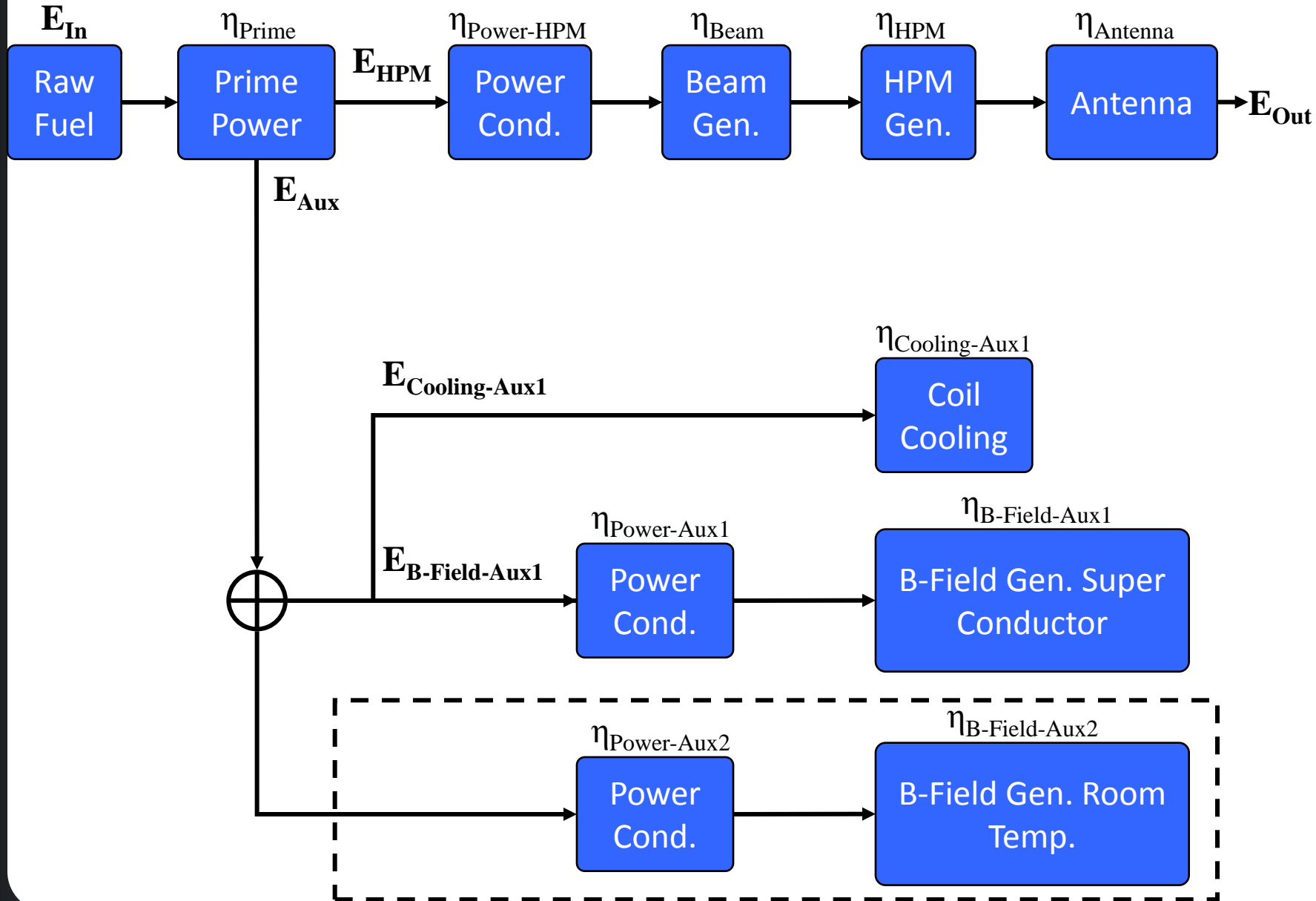

# Pulsed B-Field – $\eta_{\text{B-Field-Aux2}}$

- Energy Required
  - Dependent on the peak magnetic field required
- System Properties
  - $E_{\text{B-Field}} = E_{\text{Capacitor}} - E_{\text{Loss}}$
  - B-Field Pulse Length ( $\tau_{\text{B-Field}}$ ): 100 $\mu\text{s}$  to 1ms
  - HPM Pulse Length ( $\tau_{\text{HPM}}$ ): < 1 $\mu\text{s}$
  - System Parameters dictate that the B-Field pulse ( $\tau_{\text{B-Field}}$ ) will be on the order of 100 time longer than the HPM pulse
- Energy Efficiencies
  - 0.1% to 0.5%

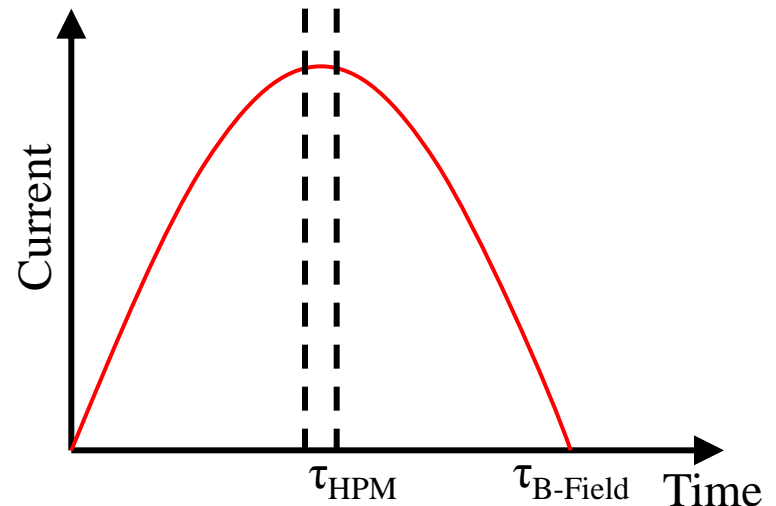
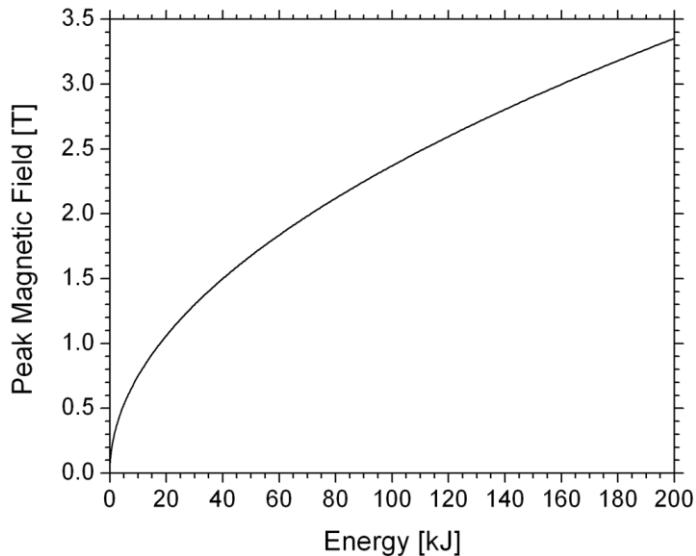

# Simple HPM System

- In the simplest configuration, no auxiliary sub-systems are needed

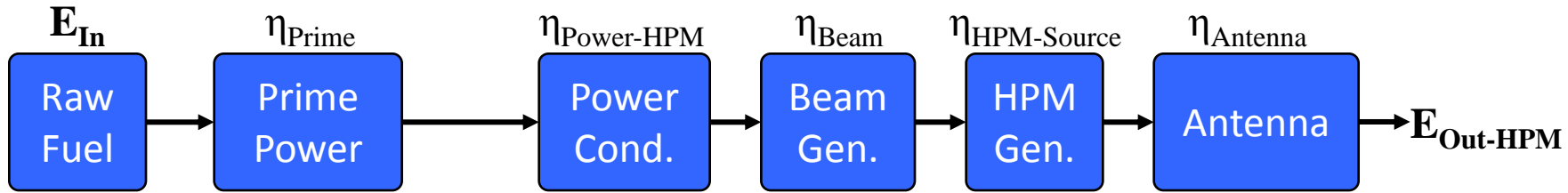

- The system energy efficiency can be calculated directly:

- $\eta_{HPM-Total} = \eta_{Power-HPM} \eta_{Beam} \eta_{Source-HPM} \eta_{Antenna}$

- $E_{Out-HPM} = \eta_{Prime} \eta_{HPM-Total} E_{In}$

- $E_{Out-HPM} / E_{In} = \eta_{Prime} \eta_{HPM-Total}$

- Best Case:

- $\eta_{HPM-Total} = (0.9)(0.9)(0.25)(0.8) = \mathbf{16.2\%}$

- $E_{Out-HPM} / E_{In} = (0.5)(16.2) = \mathbf{8.1\%}$

- Worst Case:

- $\eta_{HPM-Total} = (0.6)(0.9)(0.0025)(0.5) = \mathbf{0.0675\%}$

- $E_{Out-HPM} / E_{In} = (0.4)(0.000675) = \mathbf{0.027\%}$

# Effect of Auxiliary Systems

- Energy Consumption Ratio,  $X_{\text{Prime}}$ 
  - Only applies to systems that require externally generated magnetic field
  - Must be estimated to determine true energy efficiency

- $\eta_{\text{HPM-Total}} = \eta_{\text{Power-HPM}} \eta_{\text{Beam}} \eta_{\text{Source-HPM}} \eta_{\text{Antenna}}$

- $E_{\text{Out-HPM}} = \eta_{\text{HPM-Total}} \cdot E_{\text{HPM}}$

- $\eta_{\text{Prime}} \cdot E_{\text{In}} = E_{\text{Aux}} + E_{\text{HPM}}$

- $E_{\text{Aux}} / E_{\text{HPM}} = X_{\text{Prime}}$

- $E_{\text{HPM}} = \eta_{\text{Prime}} \cdot E_{\text{In}} / (1 + X_{\text{Prime}})$

- $E_{\text{Out-HPM}} = \eta_{\text{HPM-Total}} [\eta_{\text{Prime}} \cdot E_{\text{In}} / (1 + X_{\text{Prime}})]$

- $E_{\text{Out-HPM}} / E_{\text{In}} = \eta_{\text{HPM-Total}} \eta_{\text{Prime}} (1 + X_{\text{Prime}})^{-1}$

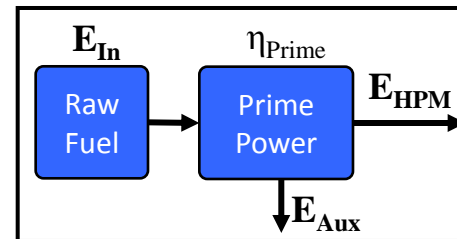

# Idealized HPM System – Case 1

- Case 1: Super Conducting Magnet
  - HPM Generation
    - Desired Output Energy = 1GW for  $1\mu\text{s} = 1\text{kJ}$
    - Best Case:  $\eta_{\text{HPM-Total}} = 16.2\%$
    - Worst Case:  $\eta_{\text{HPM-Total}} = 0.0675\%$
  - Cooling system
    - Best Case: 171MJ (5hr cool-down, 1min Operation)
    - Worst Case: 476MJ (15hr cool-down, 1min Operation)
  - Magnet Power Supply
    - Best Case: 51kJ (5min ramp-up, 1min Operation)
    - Worst Case: 510kJ (5min ramp-up, 1min Operation)
  - Best Case (Single Shot)
    - $E_{\text{Out-HPM}} / E_{\text{In}} = 3 \times 10^{-4} \%$
  - Worst Case (Single Shot)
    - $E_{\text{Out-HPM}} / E_{\text{In}} = 8 \times 10^{-5} \%$



# Idealized HPM System – Case 2

- Case 2: Pulsed Electromagnet
  - HPM Generation
    - Desired Output Energy (Single Shot) = 1GW for 1 $\mu$ s = 1kJ
    - Best Case:  $\eta_{\text{HPM-Total}} = 16.2\%$
    - Worst Case:  $\eta_{\text{HPM-Total}} = 0.0675\%$
  - Magnet Power Supply
    - Best Case
      - 20kJ for 1T
      - 10 HPM pulses per 1 magnetic pulse
    - Worst Case
      - 1 MJ for 3T
      - 1 HPM pulse per Magnetic pulse
  - Best Case (Single Shot)
    - $E_{\text{Out-HPM}} / E_{\text{In}} = 6.1\%$
  - Worst Case (Single Shot)
    - $E_{\text{Out-HPM}} / E_{\text{In}} = 0.016\%$



# Conclusions

- HPM generation systems vary widely
- Presently utilized power efficiencies are only a small part of the equation
- For self contained system that can be operated in the field
  - Energy efficiency is critical
  - Auxiliary systems play a large role in efficiency
- This framework has been presented to begin developing more accurate HPM system efficiency models



# Extra Slides

# Permanent Magnets

- Solenoid
  - 15.2 cm of four-65 turn layers
- Neodymium Magnets
  - 14 magnets
  - 3 mm length
  - 3 mm spacing
- Ceramic Magnets
  - 6 groups of 2
  - 5.7 mm length
  - 5.7 mm spacing
- Alnico Magnets
  - 5 groups of 7
  - 3 mm length
  - 3 mm spacing

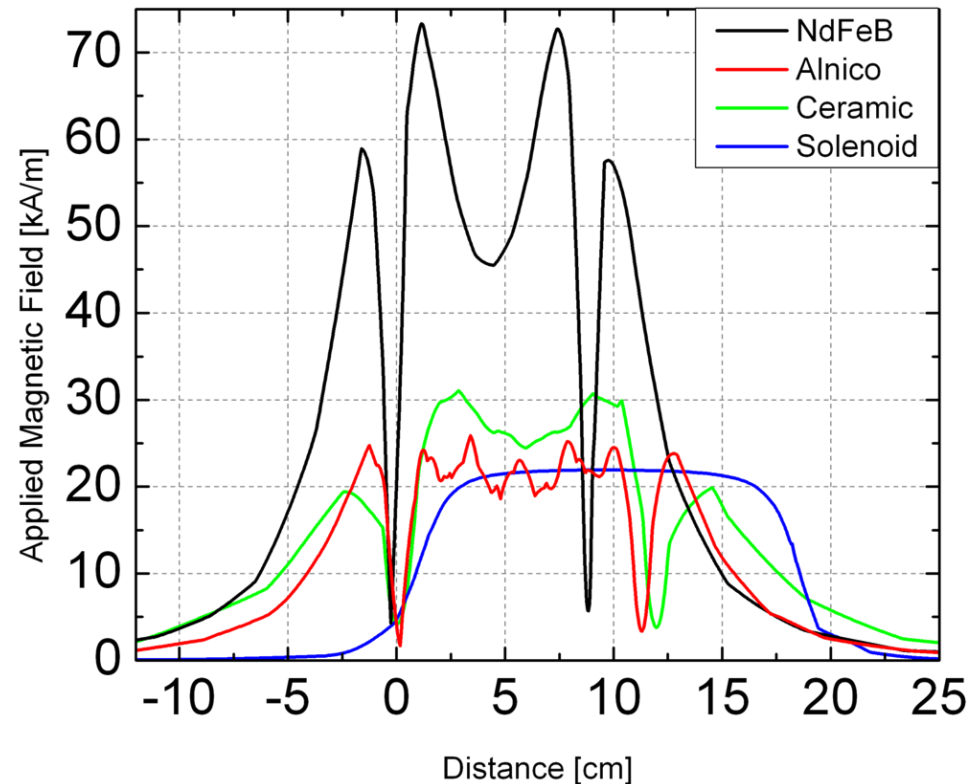



# Power Conditioning Efficiency – $\eta_{\text{Power}}$

- Power Conditioning Systems
  - Marx Generator
    - Multiple Spark Gaps
    - System Impedance
    - Requires pulse shaping component (such as PFL)
  - Linear Transformer Driver (LTD)
  - Pulse Forming Line (PFL) with Switch
    - Impedance Matching
  - Pulse Forming Network (PFN) with Switch
    - Impedance Matching
  - Capacitive Store
    - Limited Voltage
  - Modulator
    - Limited Voltage
    - Switching/Core Losses



# Super Conductor B-Field – $\eta_{\text{B-Field-Aux1}}$

- Advantages
  - Large, Uniform, Stable Electric Fields
  - Persistent mode operation
    - No additional energy needed after ramp up
      - Excluding Cooling
- Disadvantages
  - Magnetic Quenching
    - System Must be brought online slowly
      - On the order of minutes to hours
  - Cooling Requirements
    - Magnet must be continuously cooled
- Energy Efficiency
  - >95% for just the coil
- Energy Requirements
  - Dependent on the desired B-field

# Pulsed B-Field – $\eta_{B\text{-Field-Aux2}}$

- Design Considerations
  - Field Strength Required: 0.5T to 3T
  - Coil Dimensions (Tube Dimensions)
  - Capacitor Bank (Energy Requirements)
    - 40kV to 100kV
    - 40 $\mu$ F to 100 $\mu$ F
  - Pulse length required
  - Increased efficiency by multiple HPM pulses per B-field pulse

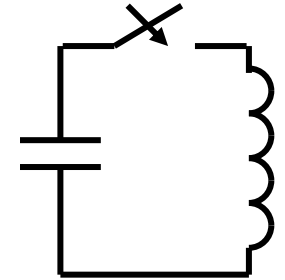

**Example:** 12in Diameter, 24in Length, 50 $\mu$ F, 60kV

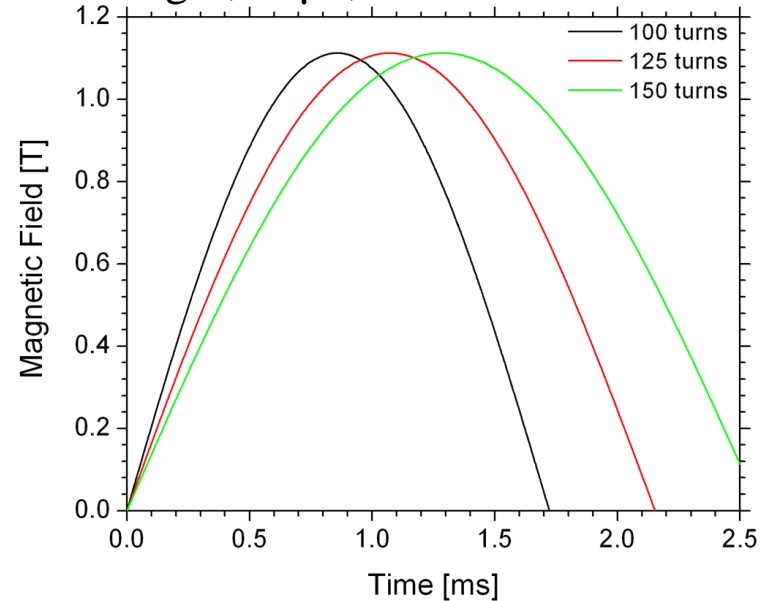
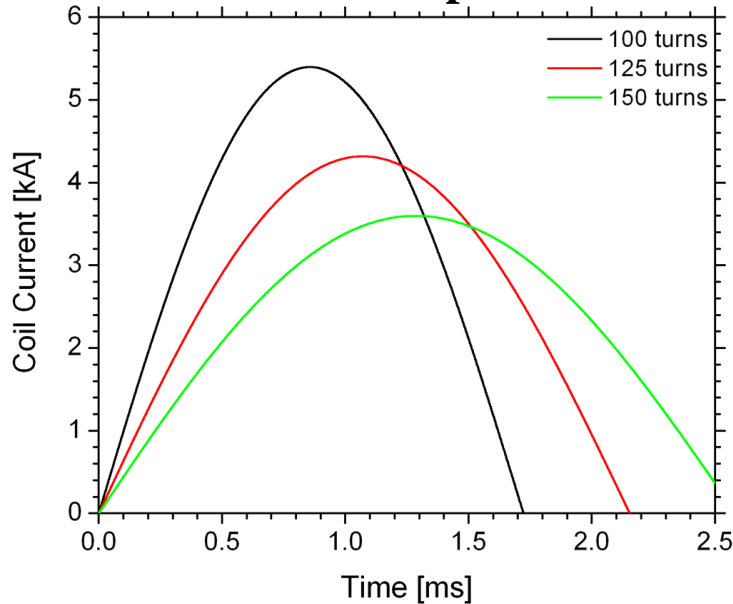



# HPM Source Efficiency – $\eta_{\text{HPM}}$

- Other HPM Sources
  - Driving pulse width vs. HPM pulse width
    - Typically 2 to 10 longer driving pulse
    - Assuming ideal square pulses
      - Energy efficiencies from 10% to 50%
  - Source efficiency during HPM generation
    - Magnetron – 20% to 30%
    - MILO – 1% to 10%
    - Klystrons – 35% to 60%
    - Reltrons – > 50%
    - Vircator – 1% to 10%
  - Overall source efficiency
    - 0.1% to 30%